

Capacitor type sag compensator



SB Series 19 inch rack mounted type



■ Benefits

- 10 years maintenance free
- Smaller footprint and lighter weight
- Uninterruptable compensation (response time within 2 msec)

■ Features

- Superior TCO (Total Cost of Ownership) , Low running cost
- Off-line circuit configuration realize high efficiency (More than 95%)
- No need for external bypass unit, by high inrush current withstand
- Applicable standards ; SEMI-F47, UL standard, CE marking, KC marking



■ Technical Specifications

Input AC	Input voltage	100V			200V			
	Allowable input voltage	93-120V			186-264V			
	Phase	Single phase 2wires						
	Frequency	50 / 60Hz						
	Capacity (Max.)	1.4kVA	2.8kVA	4.3kVA	1.4kVA	2.8kVA	4.3kVA	5.8kVA
Output AC	Rated capacity	1.2kVA	2.4kVA	3.6kVA	1.2kVA	2.4kVA	3.6kVA	4.8kVA
	Rated current	12A	24A	36A	6A	12A	18A	24A
	Rated power factor	0.8						
	Allowable power factor	0.7-1.0						
	Response time	Uninterruptible compensation						
	Compensation time	1.0 sec			0.5sec	1.0 sec		
	Repeat tolerance	100% drop / 10sec, continuous 5 times during 0.3sec						
	Overload tolerance	150% (1min), 600% (1 cycle)						
Efficiency	Over 95%							
Main unit	Cooling	Natural air						
	Dimensions : WHD (mm)	482x88x406	483x132x636	23	482x88x406	21	482x132x636	23
	Weight (kg)	8.4	18	23	8.4	21	23	
Environment	Condition	Indoor						
	Operation temperature	0 - 40°C						
	Operation humidity	30 - 90%RH						

Note) The contents are subject to change without prior notice.

■ Typical Applications

- Semiconductor / LCD / Film / Food and beverage / Pharmaceuticals
- Conveyor / Precision processing equipment / Injection machine / Robot / Contactor

■ Dimmensions

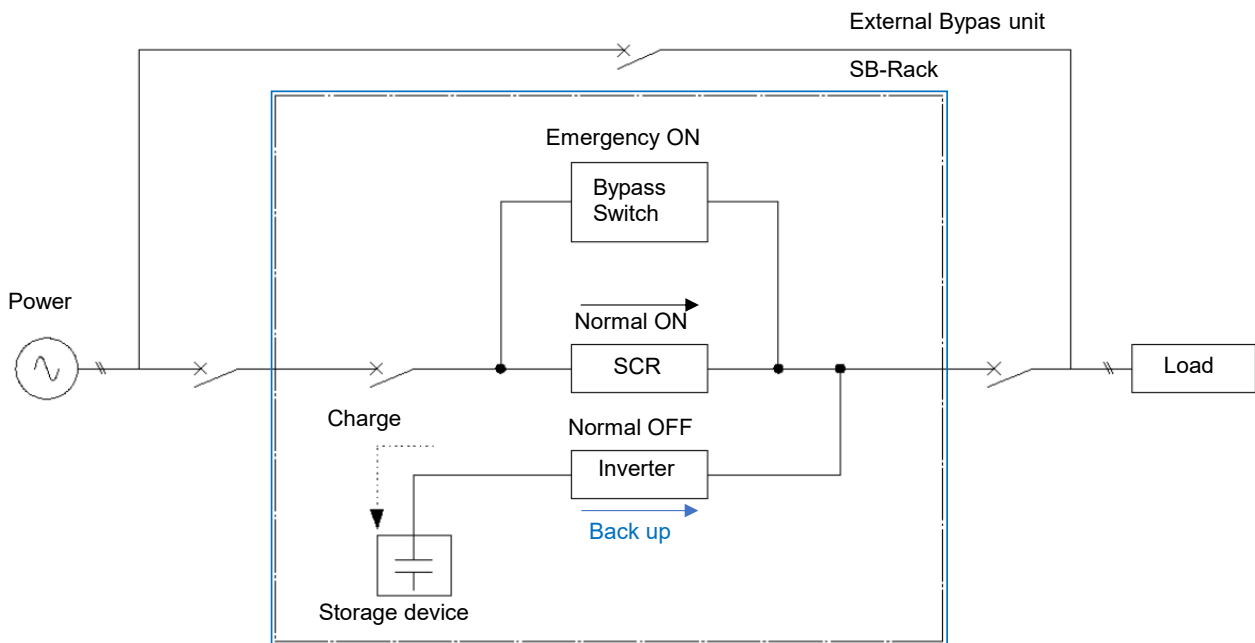
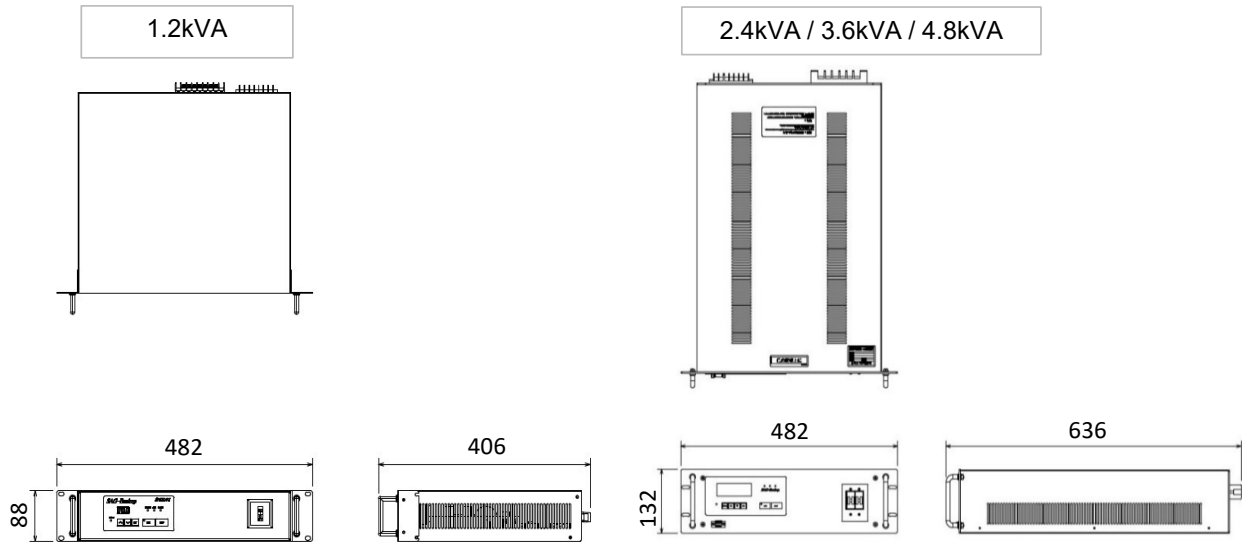

Overseas Sales & Marketing Department (Japan)
 4th Floor, Kanda Sudacho Square Building,
 1-1 Kanda Sudacho, Chiyoda-ku, Tokyo 101-0041 Japan
 TEL: +81-3-5289-8030 Email : global_tokyo@shizuki.co.jp



<http://www.shizuki.co.jp/english/>

SHIZUKI ELECTRIC CO., INC.

Note) The contents are subject to change without prior notice.